

TYPE E-1 CURB

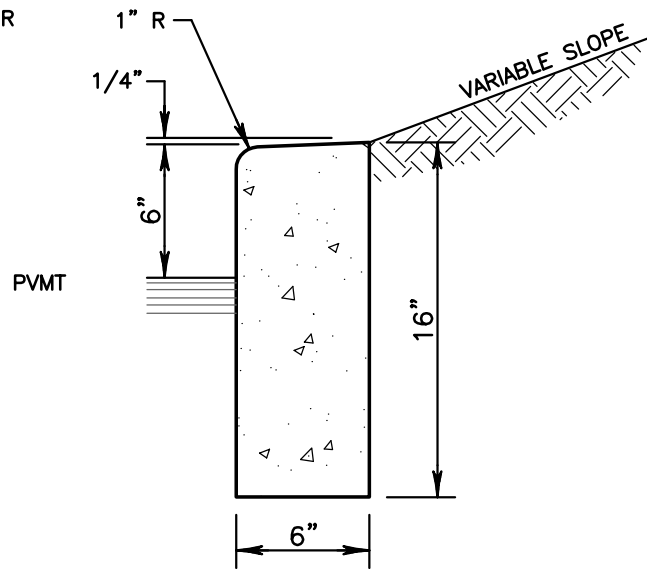

TYPE E-2 CURB

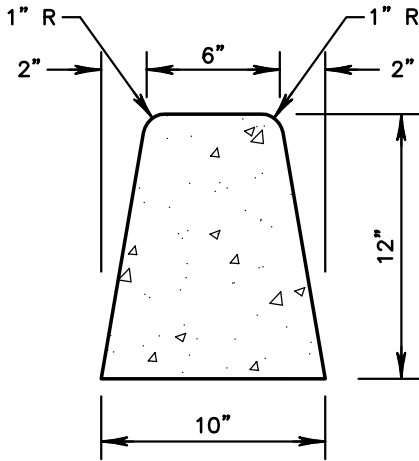

TYPE E-3 CURB

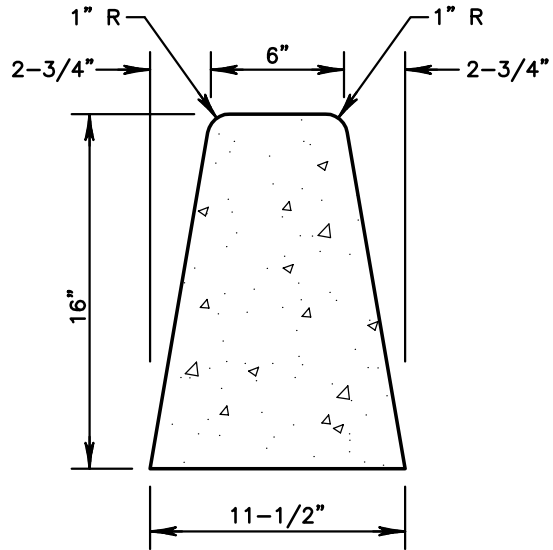

TYPE E-4 CURB

NOTES

- 1 3/8" OR 1/2" x 2" DUMMY JOINTS SHALL BE PLACED ON 10 FOOT CENTERS. JOINT SPACING MAY VARY (IN A CONSISTENT MANNER, 10' ±1') TO AVOID SHORT (<5') SEGMENTS.
- 2 ALL JOINTS SHALL BE CLEAN AND EDGED.
- 3 CONCRETE SHALL BE CEMENT CONCRETE, CLASS 4000 FROM AN APPROVED SUPPLIER.
- 4 FINISH SHALL BE LIGHT BROOM FINISH.
- 5 THE FINISHED CURB SHALL BE SPRAYED WITH A TRANSPARENT CURING COMPOUND AND COVERED BY WATERPROOF PAPER OR PLASTIC MEMBRANE IN THE EVENT OF RAIN OR OTHER UNSUITABLE WEATHER. CURING TIME SHALL BE A MINIMUM OF 72 HOURS.



City of Covington
 Public Works
 Community Development

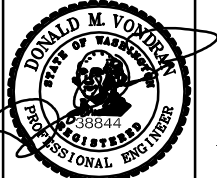

**CONCRETE CURB
 TYPES E-1, E-2, E-3 & E-4**

This document has been signed electronically in accordance with WAC 196-23-070 and Chapter 19.34 RCW. Unauthorized alteration of any of the information on this document will invalidate the document, my certification and signature.

324

Revision Date
 July 2009